



PATIO COVERS

INFORMATION
BULLETIN

3

JANUARY 2011

Development Services Department / Planning Division
3232 Main Street, Lemon Grove, CA 91945
Phone: 619-825-3805 Fax: 619-825-3818
www.lemongrove.ca.gov

This Information Bulletin describes the minimum requirements for obtaining patio cover permits for residential buildings using this information bulletin, International Code Council Evaluation Services (ICC-ES) reports, or designed using conventional light-frame wood construction.

I. DEFINITION

- A. Patio covers are one-story structures not more than 12 feet in height above grade and used only for recreational, outdoor living purposes and not as carports, garages, storage rooms or habitable rooms.
- B. Patio covers may be attached or detached and are permitted only as accessory to dwelling units such as one-or two-family dwellings or lodging houses or to individual dwelling units in multiple dwelling-unit buildings.
- C. Patio covers must be open on one or more sides. (CBC Appendix I section 102 and 103).
 1. Patio structures may extend over existing exterior wall openings.
 2. Patio covers shall not be enclosed in any manner and shall remain open when exterior openings in an existing building provide access for emergency egress or rescue from sleeping rooms.
 3. An enclosed patio structure is permitted if it covers exterior wall openings that only provide light and ventilation for the residents.
 4. Openings surrounding patio covers may be enclosed by the following methods: (a) insect screening, (b) approved translucent or transparent plastic not more than 0.125 inches in thickness, (c) glass conforming to the provisions of Chapter 24, or (d) any combination of the noted methods.
 5. Means of egress conforming to the requirements of Chapter 10 are to be provided from the enclosed patio structure.
 6. Enclosure walls must have a clear height of not less than 6'-8" measured from the floor to the soffit of the supporting members.
 7. Enclosure walls may have any configuration, provided at least 65 percent of the total wall area of the longer wall and one additional wall is open.

A final inspection must be approved before the work is considered complete by the City of Lemon Grove.

Documents Referenced in
this Information
Bulletin:

- 2010 California Building Code (CBC)

II. PROJECT FEES

Fees which include Plan Check, Permit and Inspection are charged at initial review.

III. DRAWINGS TO PROVIDE/FORMS TO COMPLETE

Plans must be drawn to scale and must be of sufficient clarity to indicate the location, nature, and extent of the work proposed. Be sure to clearly label all existing and proposed construction.

Plans must show, in detail that the proposed work will conform to the provisions of the 2010 California Building Code, Zoning Ordinances, and all other relevant laws, ordinances, rules, and regulations.

A. Site Plan

Three copies of a site plan are required for a permit. You must include information on each of the following items on the plot plan:

1. Name of owner.
2. Address and Accessor's Parcel Number where the patio is to be built.
3. Legal description of property.
4. North arrow and scale. Suggested scale: 1 inch equals 20 feet.
5. Boundaries and dimensions of property.*
6. Names of bordering streets.*
7. Width of alley(s), if any.*

8. Location and width of easements. Private easements should be shown on the property's deed.*
9. Location and dimensions of existing buildings, structures, retaining walls, paved parking, and driveways. Include distance from property lines.
10. Location and dimensions of proposed patio.

B. Foundation and Framing Plans

Provide three copies of this information bulletin or (ICC-ES) evaluation reports approved plan available from your material supplier is used for the patio design.

If plans have to be submitted because of customized design of the patio, provide three copies of plan documents. These plans should include a roof framing plan, foundation plan, elevations, cross-sections, connection details, and structural calculations.

C. Floor Plan

For patio covers within 6'-0" of a dwelling, include a floor plan and show the following information:

1. Use and dimensions of all rooms adjacent to the patio cover.
2. Size and type of all windows and doors from those rooms.

D. Permit Application

All projects must be submitted with a Permit Application. If you intend to obtain your permit on the same day as plan review, the application must be fully completed.

Note: There are no exceptions to the Workers Compensation Insurance requirements. If the property owner is doing the construction work or is hiring a number of different contractors, a separate Owner-Builder Verification form must be signed by the owner before the permit can be issued.

IV. ADDITIONAL REGULATIONS

- A. This information bulletin recommends that all patio structures be located at least 5 feet from assumed or real property lines.

Additional requirements of the building code related to fire separation distance, opening protection and parapet requirements may need to be addressed, based on the distance of the patio structure from real or assumed property lines. Such requirements include limitations on new and existing exterior wall openings of 25% of the wall area, fire protection ratings of supports and walls. Refer to CBC Tables 602 and 704.8.

- B. No fire protection is required for the common wall between the dwelling unit and patio cover as they fall under the same occupancy classification.

- C. When existing wall openings are required for light and/or ventilation within the dwelling unit itself and they open into a patio cover, the minimum ceiling height of the patio structure shall be 7'-0" measured from the floor surface to the underside of the rafters. When no required openings exist in the common wall, the minimum required height for the patio cover may be 6'-8". (CBC Appendix I section 102).

- D. All electrical wiring and equipment must comply with regulations for exterior installation.

- E. Patio covers may be located within a required side yard or rear yard, subject to the following requirements:

1. The patio structure shall not be located closer than 5 feet to any property line;
2. The patio shall be open on at least three sides except for support columns with maximum dimensions of 18 inches by 18 inches in plan view;
3. The support columns shall have a minimum separation of 8 feet measured on center.
4. The height of the roof of the patio shall not exceed the roof eave or the sill plate of the second floor, whichever is lower.

- F. Structures located in a Very High Fire Hazard Severity Zone or Brush Management Zones, governed by the City of Lemon Grove Brush Management Ordinance, may need to meet additional fire protection requirements.

V. CONSTRUCTION SPECIFICATIONS

Following are the minimum construction specifications for patio covers:

- A. The concrete mix for footings must meet a compressive strength of $f'c = 2,500$ psi minimum.

- B. Lumber must be Douglas fir-larch No. 2 or better. All lumber must be grade-marked. Joists, girders, and posts may be required to be protected against decay and termites.

- C. Post size is based on the height of the floor above the slab (at the highest point):

- 0 to 8 feet high: 4x4 minimum,
- 8 to 10 feet high: 6x6 minimum

D. The post anchorage and bracing details shown on the following sheets have been approved by the City of Lemon Grove for unenclosed patio covers.

1. Posts must be anchored at the lower end and must be braced at the upper end using any of the details shown in Figure
2. Post anchorage to slabs may be accomplished with a standard approved post base installed per the manufacturer's installation instructions. The footing must be adequate for the load applied. See Section IX below and Table A. When the load on supporting post does not exceed 750 pounds per posts, a minimum 3 1/2-inch-thick concrete slab-on-grade may be substituted for the pad footings shown on the typical framing details. (CBC Appendix I104.2).

E. When it is desired to connect and support one side of the patio cover structure by attaching it directly to the dwelling unit, the rafter spacing and beam sizes may be as shown in Tables B and C. However, the main beam may be replaced on the side attached to the dwelling unit with a ledger the same size as the rafters and fastened to the studs with 3/8" x 5" lag screws spaced at 16" maximum on center. Patio rafters may not be solely supported by the existing rafter tails or fascia of the house. The size of the existing headers at openings adjoining the proposed patio covers may need to be verified base on

the configuration of an existing building and the depth of the cover.

F. Specify roof covering when submitting plans. If nominal one-half-inch-thick roof sheathing is used, the roof may have rafters spaced not more than 24" on center. Patio covers constructed of light-transmitting plastics shall comply with Sections 2606 and 2609 of the CBC and to the manufacturer's installation instructions. The corrugations must be placed perpendicular to and across the supports. Roof systems shall be sloped 1/4 inch in 12 inches for drainage.

G. Framing hardware and fasteners shall be hot-dipped galvanized or stainless steel if in preservative-treated wood. (CBC 2304.9.5).

VI. INSPECTIONS

An Inspection Record Card is issued at the time the permit is obtained. The inspector signs this card as the construction is inspected and approved. The approved plans, the Inspection Record Card, and the permit are important records and should be retained.

A combination permit is active for 180 days. Each inspection scheduled and passed extends the permit 180 days. Permits approaching expiration can be extended under special circumstances.

Inspections are required at the following times:

- A. When footing has been excavated but before concrete is placed,
- B. When ledgers are attached to an existing structure, and
- C. When work is complete.

Note: *The project is not legally complete until there is an approved final inspection.*

VII. TABLES

Tables A, B, and C make the following assumptions:

Roof live load is 10 psf.

Roof dead load is 7 psf.

All lumber is to be Douglas fir-larch No. 2 or better (repetitive member use):

F b = 900 psi, F v = 180 psi

E = 1,600,000 psi. Soil bearing pressure is 1,500 psf minimum.

If the above information differs, values in the tables must be adjusted.

Table A/Minimum Square Footing Sizes (Inches)*

Post Spacing (Feet)	Rafter Span (Feet) ^{1,2}							
	6	8	10	12	14	16	18	20
	4	S	S	S	S	S	S	S
6	S	S	S	S	S	S	S	S
8	12	12	12	12	12	14	14	14
10	12	12	12	14	14	14	16	16
12	12	12	14	14	16	16	18	18
14	12	12	14	16	16	18	18	20
16	12	14	14	16	18	18	20	20
18	12	14	16	18	18	20	20	22
20	14	14	16	18	20	20	22	24

*See dimension "A" on "Figure 5"

¹ "S" Patio supported on a concrete slab on grade without footings

² Assume reinforcing bar size #4 top and bottom, rebar yield Fy=60 ksi

Table B/Minimum Rafter Sizes (Inches)

Rafter Span (feet)	Rafter Spacing Center-to-Center (Inches) ^{1,2}			
	12	16	24	32
	(5/16" plywood sheathing)	(11/32" plywood sheathing)	(1/2" plywood sheathing)	(5/8" plywood sheathing)
6	2x4	2x4	2x4	2x4
7	2x4	2x4	2x4	2x4
8	2x4	2x4	2x6	2x6
9	2x4	2x6	2x6	2x6
10	2x6	2x6	2x6	2x6
11	2x6	2x6	2x6	2x6
12	2x6	2x6	2x6	2x8
13	2x6	2x6	2x8	2x8
14	2x6	2x6	2x8	2x8
15	2x6	2x8	2x8	2x10
16	2x8	2x8	2x8	2x10
17	2x8	2x8	2x10	2x10
18	2x8	2x8	2x10	2x10
19	2x8	2x10	2x10	2x12
20	2x8	2x10	2x10	2x12

¹ Deflection base on L/360 (LL only)

² Load Duration Factor = 1.25.

Table C/Minimum Beam Sizes (Inches)

Post Spacing (Feet)	Span of Rafters (In Feet) ^{1,2,3}								
	4	6	8	10	12	14	16	18	20
4	4x4	4x4	4x4	4x4	4x4	4x4	4x4	4x4	4x4
6	4x4	4x4	4x4	4x4	4x4	4x4	4x4	4x4	4x6
8	4x4	4x4	4x6	4x6	4x6	4x6	4x6	4x6	4x6
10	4x4	4x6	4x6	4x6	4x6	4x6	4x8	4x8	4x8
12	4x6	4x6	4x6	4x8	4x8	4x8	4x8	4x8	4x10
14	4x6	4x8	4x8	4x8	4x8	4x10	4x10	4x10	4x10
16	4x8	4x8	4x8	4x10	4x10	4x10	4x12	4x12	4x14
18	4x8	6x8	6x8	6x8	6x8	6x10	6x10	6x10	6x10
20	4x8	6x8	6x8	6x8	6x10	6x10	6x10	6x12	6x12
	6x8	6x8	6x10	6x10	6x10	6x12	6x12	6x12	6x14

¹ If joists are within 18 inches of grade, use pressure-treated. Douglas fir-larch or Foundation-Grade redwood.

² Deflection base on L/360 (LL only)

³ Load Duration Factor = 1

Figure 1 / Sample Patio Site Plan

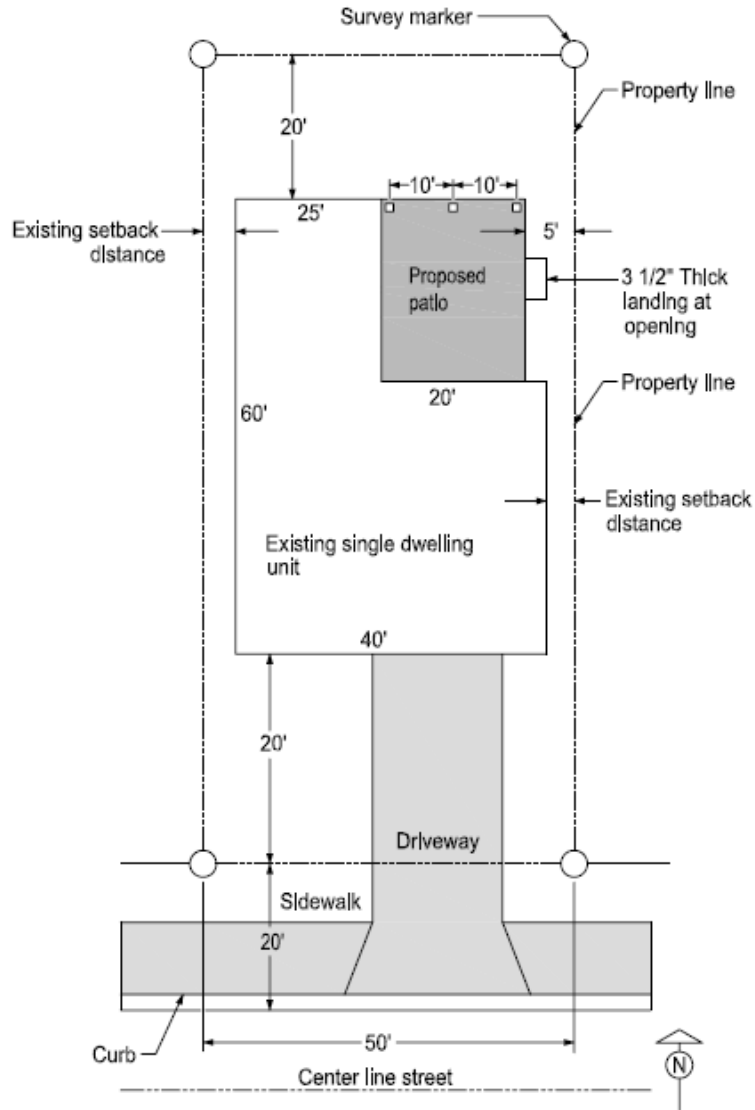

Figure 2 / Typical Patio

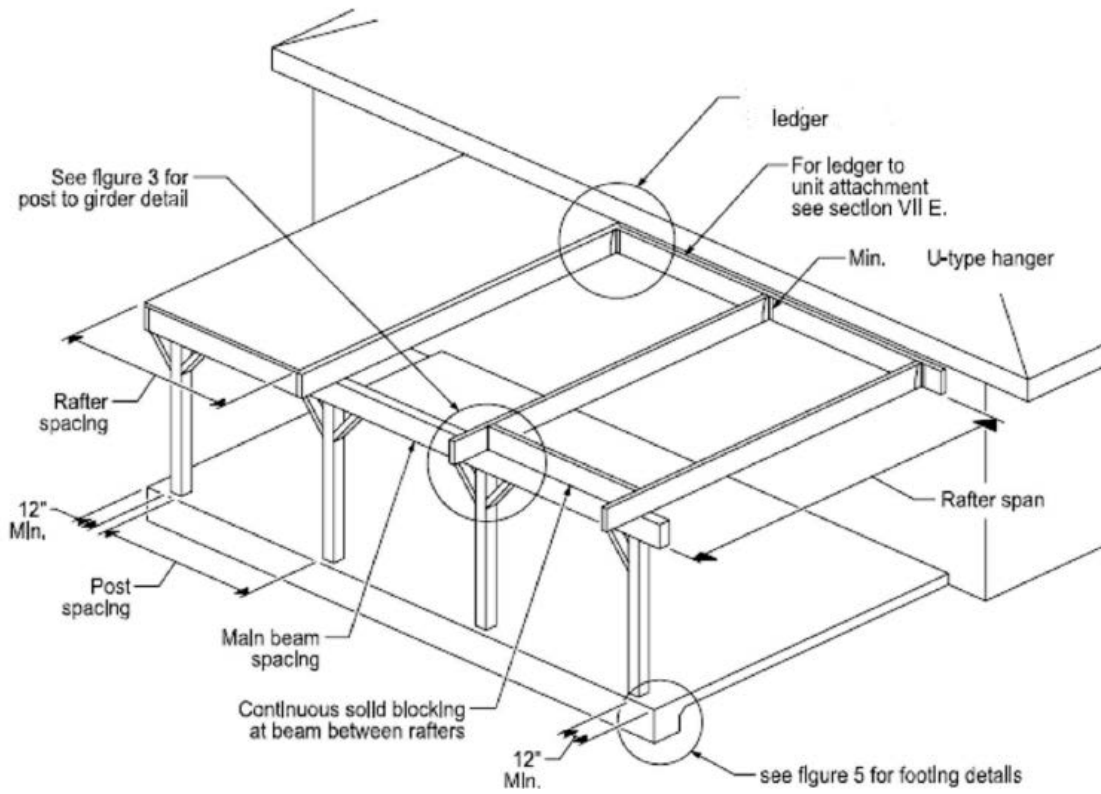

Figure 3 / Post-to-Girder Connection

Case 1 / Connection, Interior Condition

Case 2 / Interior Condition

